



Large Droplet Generator LDG 244

For special applications requiring large oil amounts a new generator for dosing coarse disperse oils (subject to utility model protection) was developed as an attachment for the SPT 140.

The LDG 244 is especially suitable for simulating gushes of oil and wall film respectively. By means of a heated single medium nozzle oil droplets with an extremely large diameter and in a substantially higher throughput mass flow compared with the performance parameters of the Atomizer ATM 243 can be generated. Withal different oils are useable.

An additional control unit enables a standalone operation of the generator independently of the test system SPT 140.

Special Advantages

- Generates polydisperse test aerosol with a mean particle size of 50 - 100 μm
- Very high particle mass flow within the range of 50 - 2000 g/h
- Very high aerosol particle concentration
- Adjustable and regulated aerosol temperature

Applications

- Testing of oil mist separators
- Capacity tests of filters
- Simulation of wall film and oil gush effects
- Research & Development

Operating Principle

The oil is nebulized by a pulsed driven single-substance nozzle with baffle.

The pressure upstream of the nozzle is adjusted by the pressure in the oil reservoir. From there the oil comes through the hose to the dosing unit, which contains heater, valve and spray nozzle.

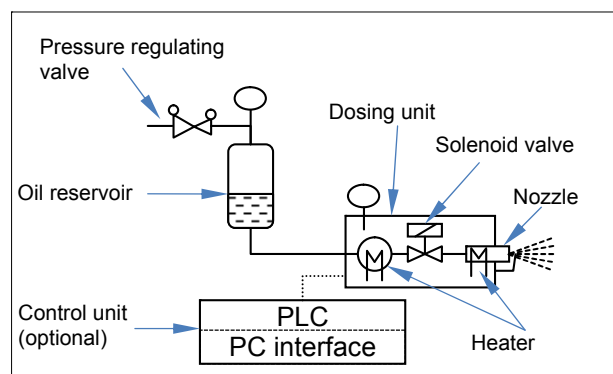

Funktional schematic

Specifications

Details

The throughput oil mass flow is adjusted by impulse operation of the single-substance nozzle. The nozzle is opened and closed periodically in short intervals, the lengths of which vary according to the desired mass flow. For further transport of the aerosol, an additional airflow at the nozzle outlet is required.

The droplet size distribution can be effected by pressure and temperature of the engine oil upstream the spray nozzle and by the dosing range of the valve.

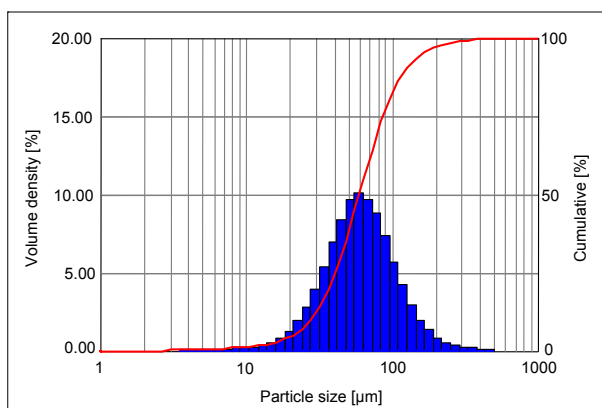

Particle size distribution of an aerosol generated by the LDG 244 generator (engine oil 0W30)

The LDG 244 is equipped with temperature limiters to avoid overheating. These safety devices switch off the heating cartridges in case of the temperature exceeding 140°C.

The optional control unit allows the independent control of the generator without the test system SPT 140.

This control unit contains all necessary components for regulating the heater temperature and controlling the valve. Furthermore it comprises an Ethernet interface to PC for input of data and controlling. The system is operated by a web-based visualization. Additional software is not necessary for this purpose.

Technical Data

Particle material	Engine oil
Mass flow	50 ... 2000 g/h
Particle size	$d_{50,3}=50\text{...}100\ \mu\text{m}$
Aerosol flow rate	Depends on the test system SPT 140; up to 300 l/h
Temperature range	Room temperature ... 120°C
Nozzle temperature	90°C ... 120°C
Nozzle switching frequency	2 Hz ... 75 Hz
Nozzle pulse length	5 ms ... 20 ms
Filling amount	0.5 l ... 2 l
Max. inlet pressure	800 kPa (8 bar)
Max. operating pressure	600 kPa (6 bar)
Power supply	100 ... 240 V AC (only required for optional control unit)
Dimensions (W x D x H)	
Oil reservoir	260 x 210 x 550 mm
Dosing unit	210 x 210 (280) x 110 mm
Weight	9.3 kg

QMS certified to
DIN EN ISO 9001.



12 100 11908 TMS

For more information please visit our website at www.topas-gmbh.de

Specifications are subject to change without notice.

© Copyright 2013 Topas GmbH.

